

# ACCA

Francesco Rota | 2017



# ACCA

Francesco Rota | 2017

The history of Lapalma is revealed in a letter. The letter "H" lends its name to the ACCA table, which turns over to become its support. Its strong character comes from the fusion of a single piece, the expertise acquired throughout forty years of experience and research. Tabletops of various dimensions and adjustable heights, created as single elements or for use as a continuum of units that adapts to all contexts, rest on this highly important coupling element. The table is fitted with electric connection points, recessed in the top, and wireless charging points to meet the needs of a contemporary work environment.



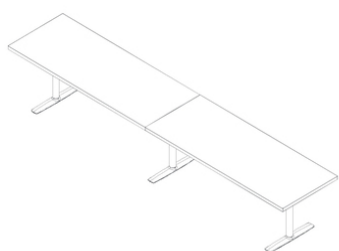

Symmetric

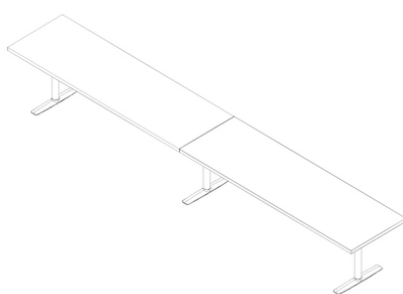

Symmetric — big

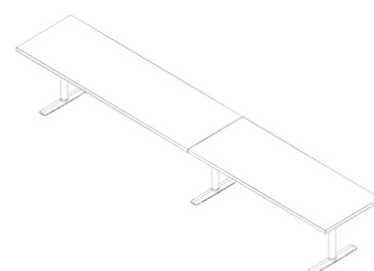

Asymmetric

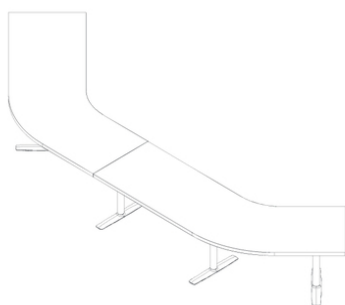

C asymmetric — open

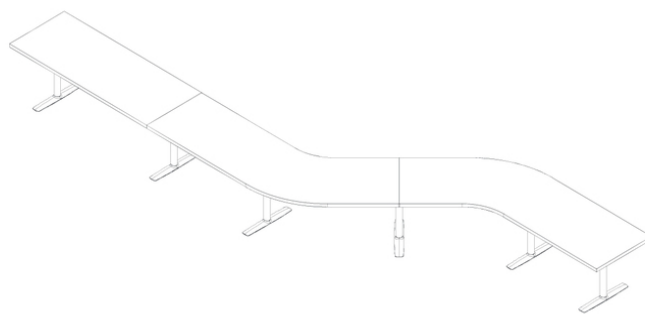

S\_shape

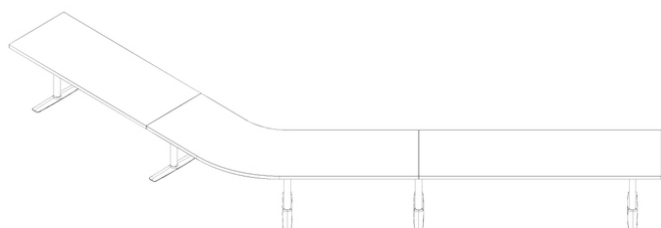

V\_shape

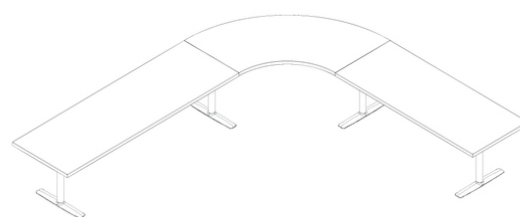

L\_shape

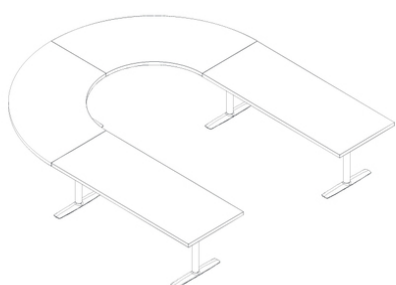

U\_shape — small

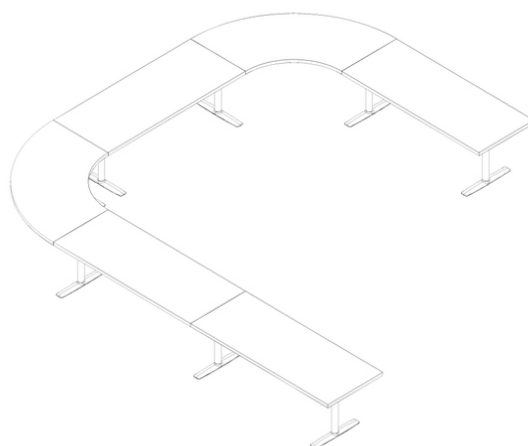

U\_shape — big

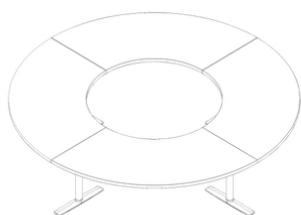

Conference — small

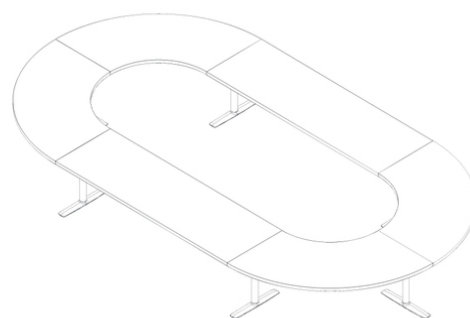

Conference — big

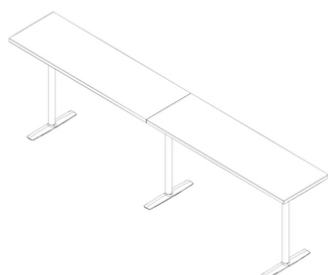

High symmetric — medium

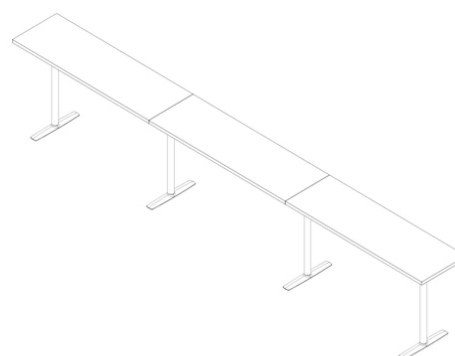

High symmetric — big

# ACCA

Francesco Rota | 2017

Table with diecast aluminium base and metal legs powder coated black or white. Height adjustable with electrical mechanism. Top in several finishes. It can be activated by a button or bluetooth via smartphone. Power 110-220 V or lithium battery. Safety system with automatic stop of the movement.

## free standing h74

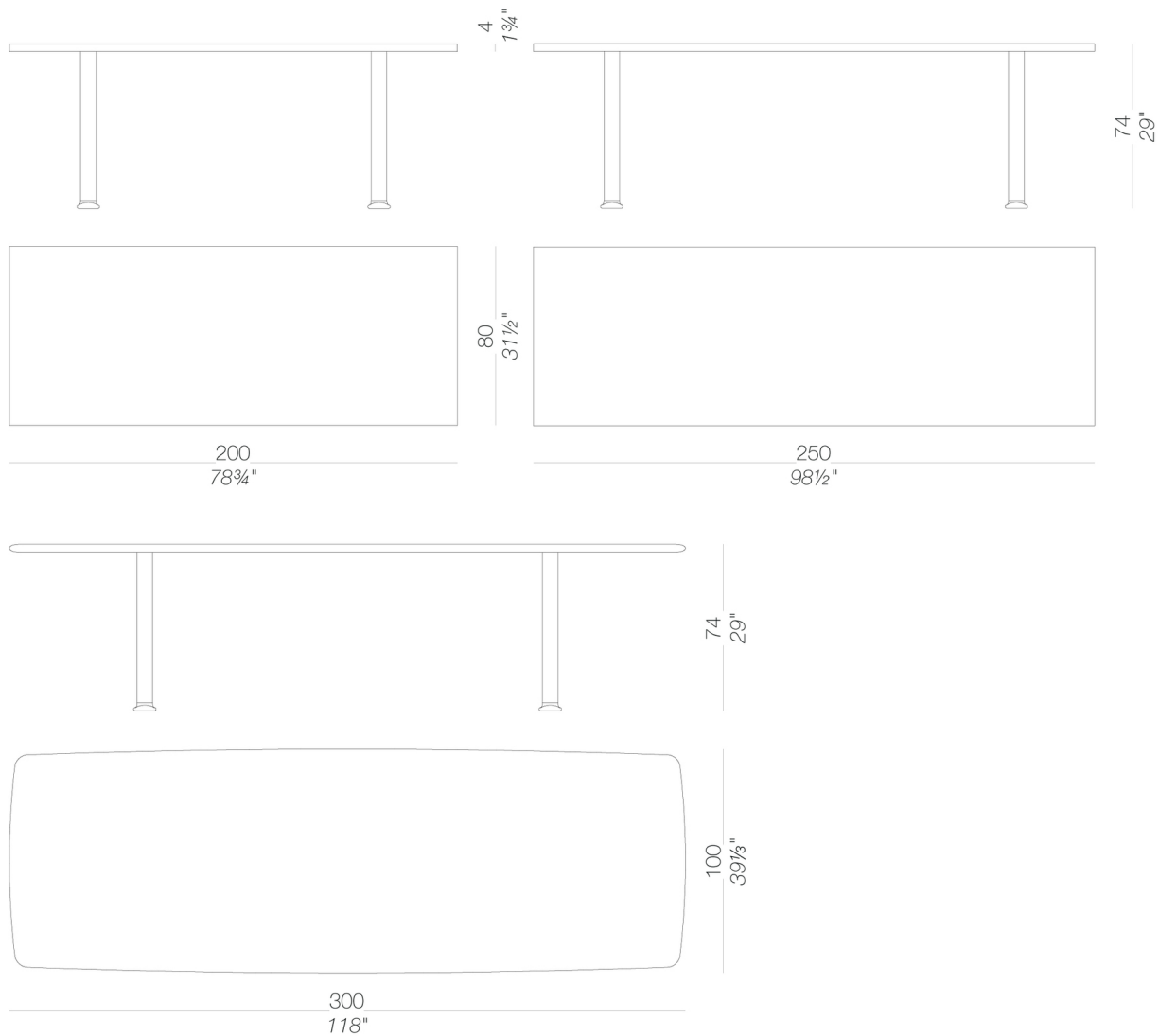

# ACCA

Francesco Rota | 2017

## modular system h74

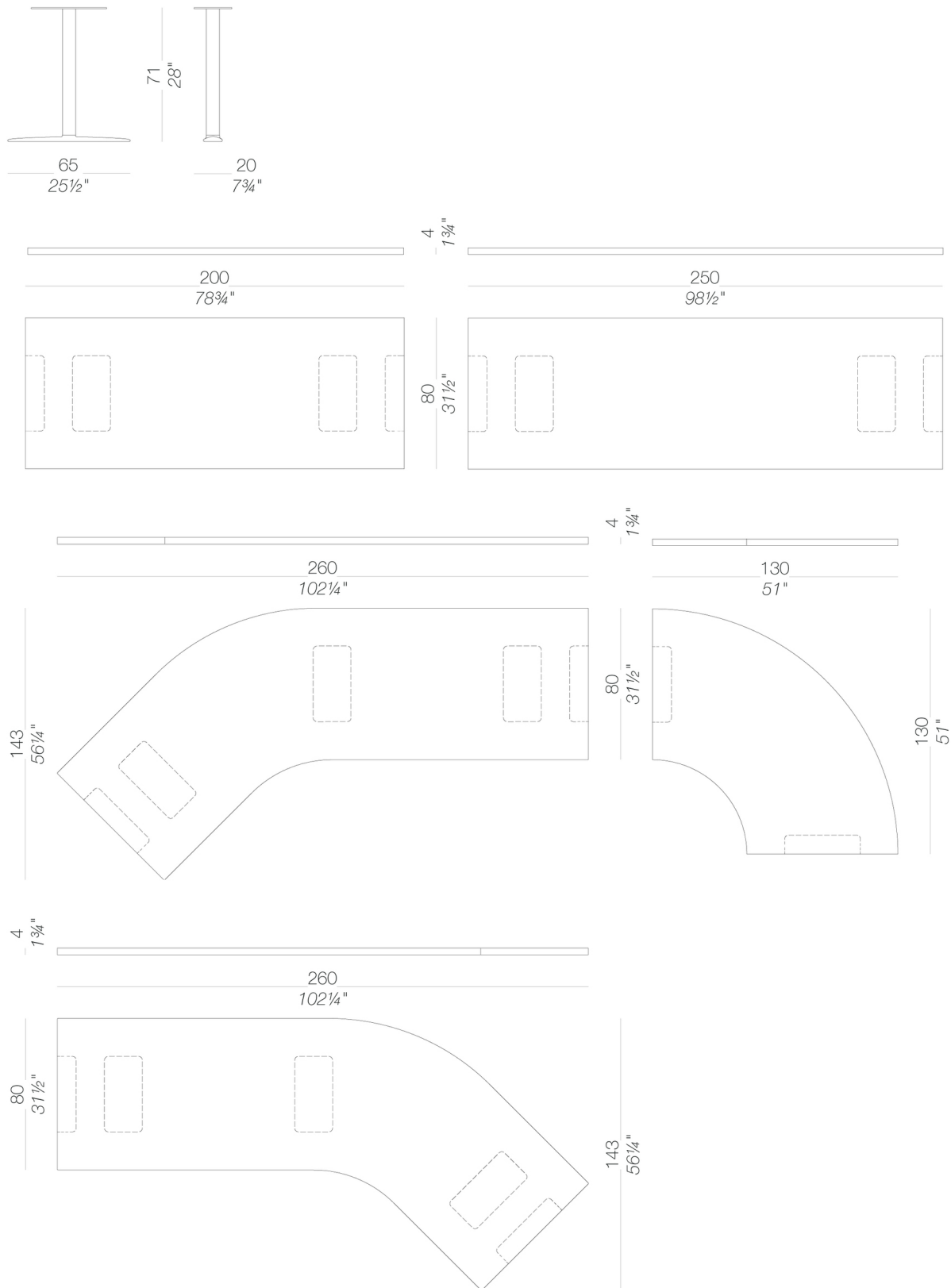

# ACCA

Francesco Rota | 2017

## mobile

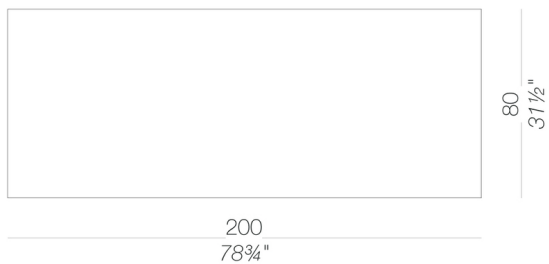
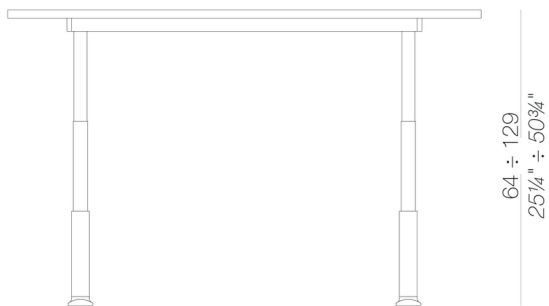

## free standing h110

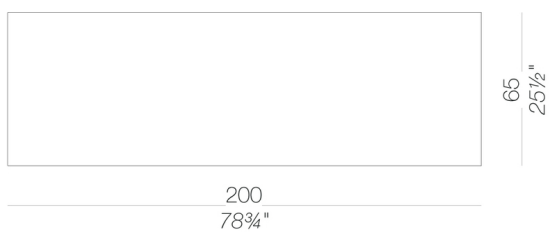
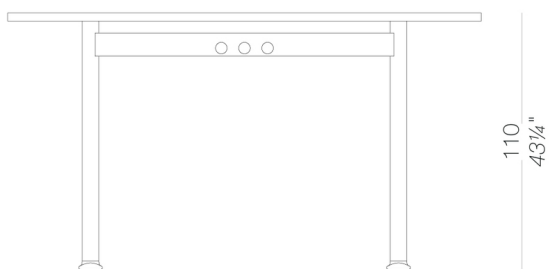

## modular system h110

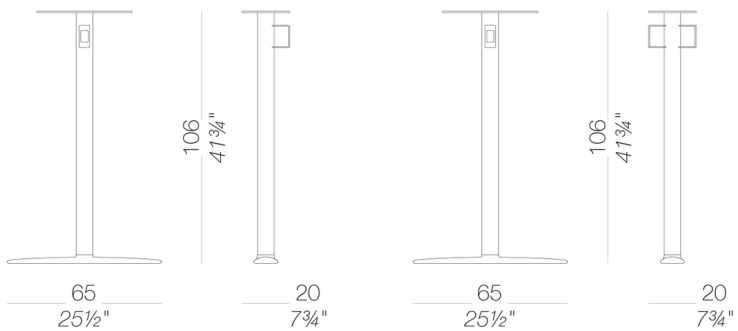

# ACCA

Francesco Rota | 2017

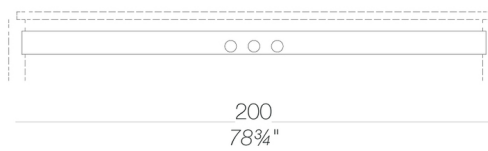
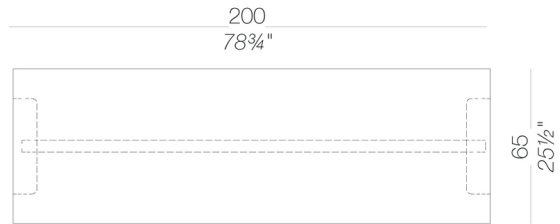
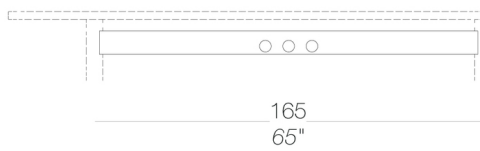
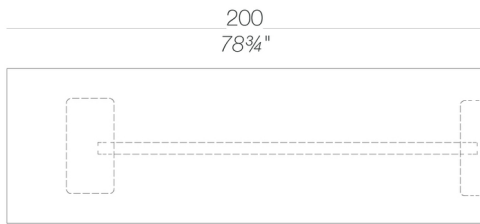
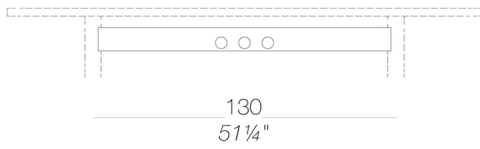
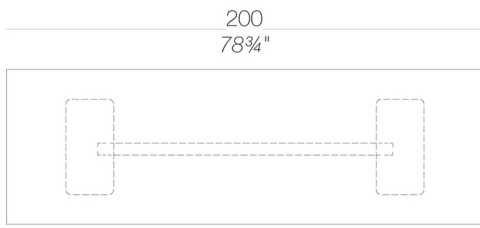



# ACCA

Francesco Rota | 2017

## frame



powder coating  
black  
1 Colors



powder coating  
white  
1 Colors

## top



laminate  
fenix 9/10  
2 Colors



wood  
blached oak  
1 Colors

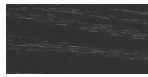

wood  
black open pore  
1 Colors

**consult the portfolio for the range of colors, fabrics, eco-leather, soft-leather.**

### use and maintenance instructions

Clean all parts in wood, leather, fabric and metal with a damp cloth or a diluted neutral cleaner. Do not use cleaners with alcohol, bleach, solvent or abrasive products. Any liquid spilt on the product must be wiped up immediately. When lifting or moving the product, hold it on the structure and not under the seat. The product should not be subjected to unbalanced weights, as it is designed for a proper rest on the foothold (on four legs or on the base). Our company relieves from any responsibility in case of damage caused to fragile floors. Avoid any improper use of the product: do not step on the product, on the footrest or on the armrests. Avoid any movements that could compromise the proper functionality of the product or the safety of the users. Wood and leather, being natural materials, could be easily damaged. Small impurities or imperfections are within quality standard range. Do not expose the product to weather conditions or atmospheric agents, nor to heat sources over 40°C. Also products for outdoor use could be afflicted by atmospheric agents. The product could undergo possible exterior changes due to particular exposure to heat, humidity and saltiness. An appropriate and frequent maintenance and cleaning of the product enhances its durability. The product could change colour and shade, if exposed to direct sunlight. Maintenance has to be carried out by experienced staff. Dispose of the package only after assembling the product, in order to avoid the loss of ironmongery and components. Once the product has been dismantled, the product itself or its components must be given to the public garbage disposal system, according to the legislation in force.