

AP

Shin Azumi | 2010

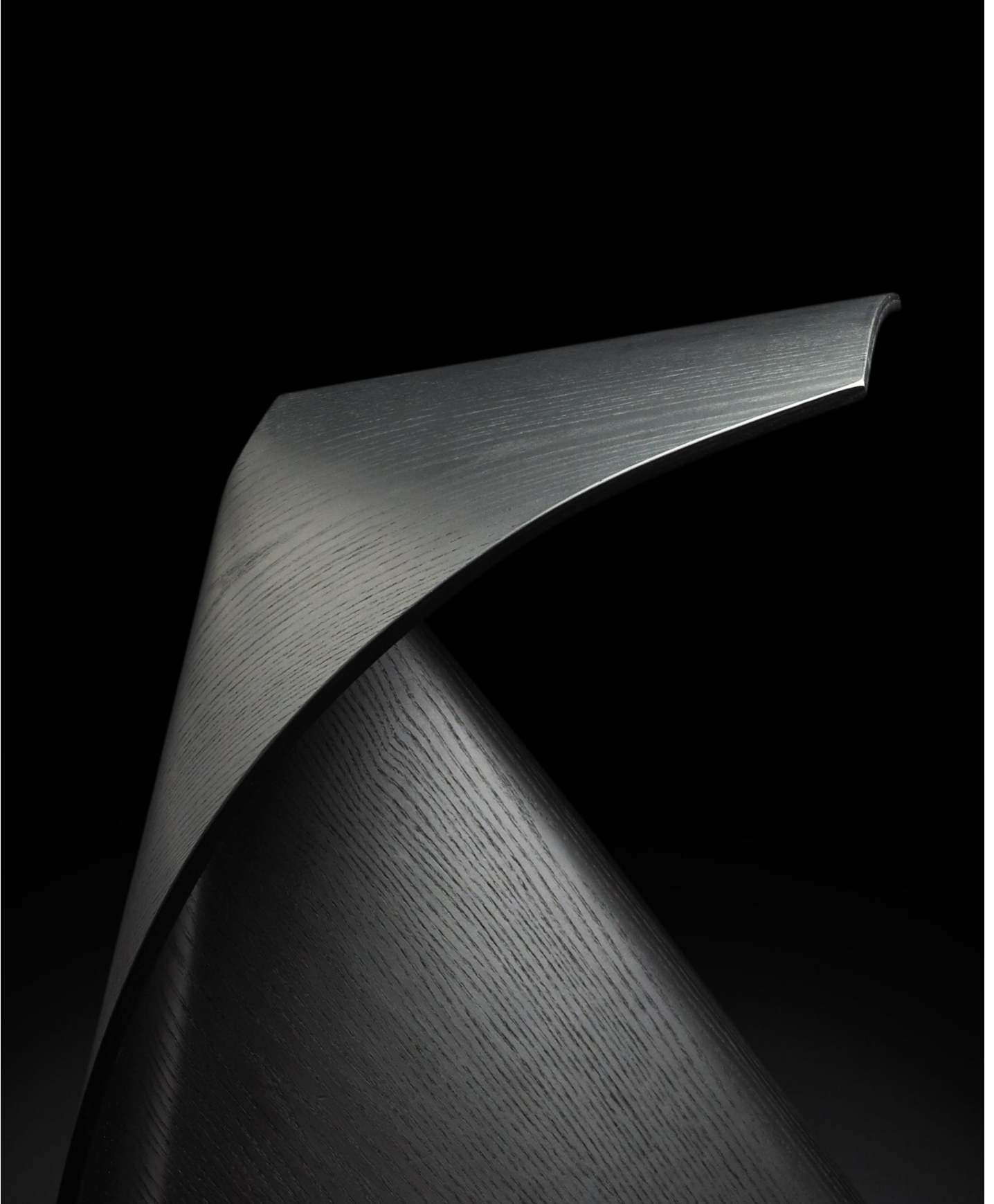

AP

Shin Azumi | 2010

A tribute to the origami tradition, this stool has been created by folding a sheet of wood. And just as the hands discover the endless shapes offered by paper and invent animals, figures and stars, the AP profile surprises with each one of its angles. The chair has powerful graphic appeal. Its lightness is a flight of butterflies.



AP

Shin Azumi | 2010



S51 In 3D processed wood

Nesting stool in moulded plywood. Available in blanché oak, stained dark walnut or black open pore.

TEST EN 1728:2000 6.2.1-6.2.2 - EN 15373:2007 - L2 general

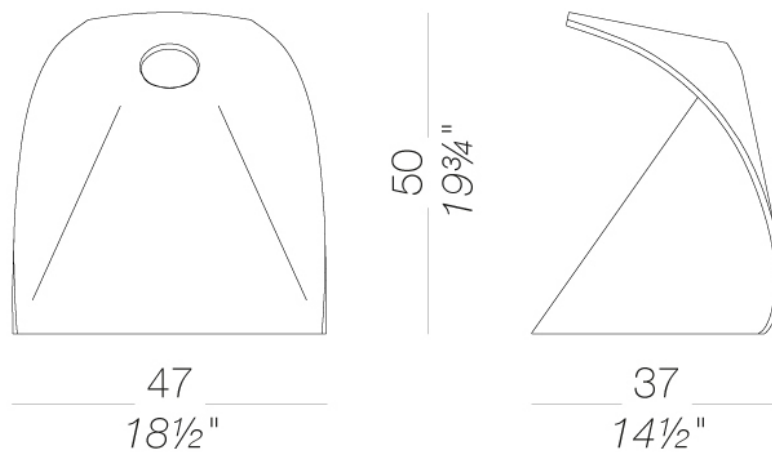

AP

Shin Azumi | 2010

frame



wood
blanch oak
1 Colors



wood
black open pore
1 Colors



wood
oak dark walnut
1 Colors

consult the portfolio for the range of colors, fabrics, eco-leather, soft-leather.

use and maintenance instructions

Clean all parts in wood, leather, fabric and metal with a damp cloth or a diluted neutral cleaner. Do not use cleaners with alcohol, bleach, solvent or abrasive products. Any liquid spilt on the product must be wiped up immediately. When lifting or moving the product, hold it on the structure and not under the seat. The product should not be subjected to unbalanced weights, as it is designed for a proper rest on the foothold (on four legs or on the base). Our company relieves from any responsibility in case of damage caused to fragile floors. Avoid any improper use of the product: do not step on the product, on the footrest or on the armrests. Avoid any movements that could compromise the proper functionality of the product or the safety of the users. Wood and leather, being natural materials, could be easily damaged. Small impurities or imperfections are within quality standard range. Do not expose the product to weather conditions or atmospheric agents, nor to heat sources over 40°C. Also products for outdoor use could be afflicted by atmospheric agents. The product could undergo possible exterior changes due to particular exposure to heat, humidity and saltiness. An appropriate and frequent maintenance and cleaning of the product enhances its durability. The product could change colour and shade, if exposed to direct sunlight. Maintenance has to be carried out by experienced staff. Dispose of the package only after assembling the product, in order to avoid the loss of ironmongery and components. Once the product has been dismantled, the product itself or its components must be given to the public garbage disposal system, according to the legislation in force.