



HORM.IT

Specchi / Mirrors

MAMANONMAMA—

Mario Botta, 2004

Inspired by daisies, the Mamanonmama (Love Me, Love Me Not) collection is composed of five petals to be placed, together or individually, on a table or on the wall. The frame, made of precious, black-willow solid wood, is perfectly attuned to the philosophy of Horm's collections.

MAMANONMAMA — Ispirata a una margherita, la collezione Mamanonmama è composta da cinque specchi a forma di petalo da disporre insieme o singolarmente su un tavolo o appesi a parete. La cornice, in prezioso legno massello di salice nero, si sposa alla perfezione con la filosofia delle collezioni Horm.

MAMANONMAMA — S'inspirant de la marguerite, la collection Mamanonmama se compose de cinq pétales à disposer ensemble ou individuellement, posés sur une table ou suspendus au mur. Le cadre, en bois massif de saule noir de grande qualité, épouse parfaitement la philosophie des collections Horm.

MAMANONMAMA — Die Kollektion Mamanonmama besteht aus fünf Blütenblättern, die sich an Margeriten inspirieren, zusammen oder einzeln platziert werden und entweder als Tisch- oder als Wandschmuck dienen können. Der massive Rahmen aus wertvollem schwarzem Weidenholz steht perfekt für die Philosophie der Horm Kollektionen.



Misure e finiture / Sizes and finishes

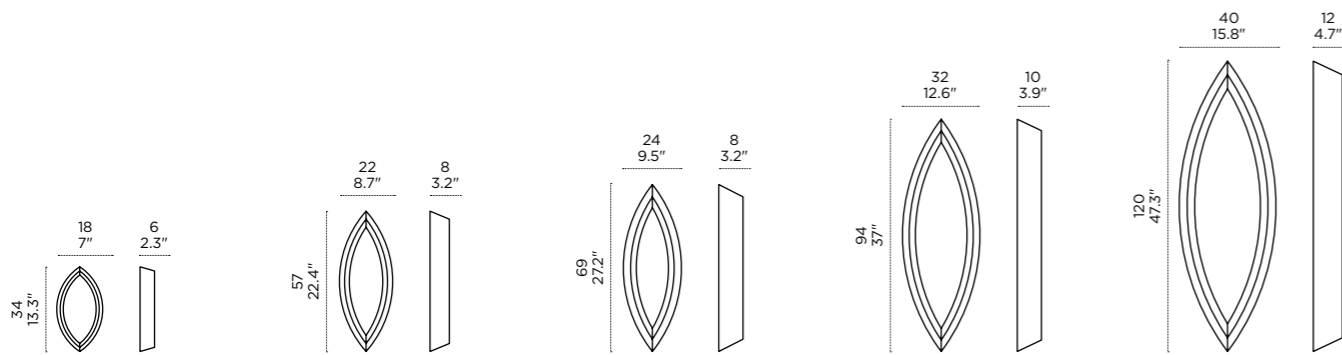

Download high resolution photographs of this product from www.photos.horm.it

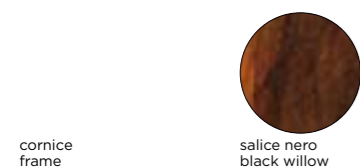

cornice
frame

salice nero
black willow





BLEND
Armadio / Wardrobe

MAMANONMAMA
Specchio / Mirror

HI-PLY
Letto / Bed

IO E TE
Comodino / Bedside Table

